



INSURAL* FURNACE LINING SYSTEM

For dosing and low-pressure aluminium furnaces



INSURAL Furnace Lining System

Pre-formed highly insulating refractory lining for aluminium furnace applications.

Sinter - or Ready-for-Use?

Traditional furnace lining systems involving the application of wet refractory mixes typically require time-consuming dry-out and sintering operations prior to metal charging. In addition to significant furnace downtime, such lining systems also typically lead to hydrogen pick-up in the aluminium melt for the initial period following furnace installation.

The INSURAL Furnace Lining System, combining highly insulating and durable components, is the ideal solution for today's aluminium melting operations. A dry, preformed engineered lining system - Ready-to-Use !

Benefits include:

- + No sintering or dry-out program
- + Reduced furnace downtime
- + Lower energy costs
- + Improved melt quality
- + Greatly reduced hydrogen evolution on start-up - rapid achievement of target melt density.
- + Low corundum growth - easy to clean and maintain

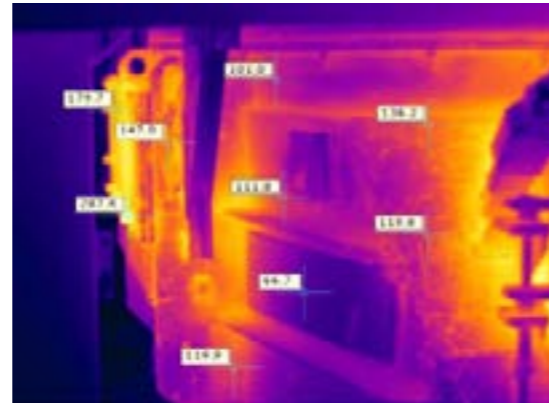

Traditional lining

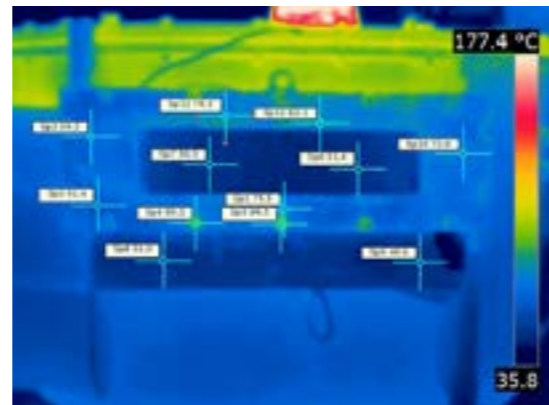

INSURAL lining

Pre-heating

This chart shows the pre-heating programs for a 650kg furnace lined with a traditional refractory lining compared to an INSURAL lined furnace.

Whereas traditional refractory furnace linings require a gradual temperature ramp up over a period of days, the INSURAL lining system can be heated directly to the normal operating temperature. A 48 hour holding time is recommended before melt charging.

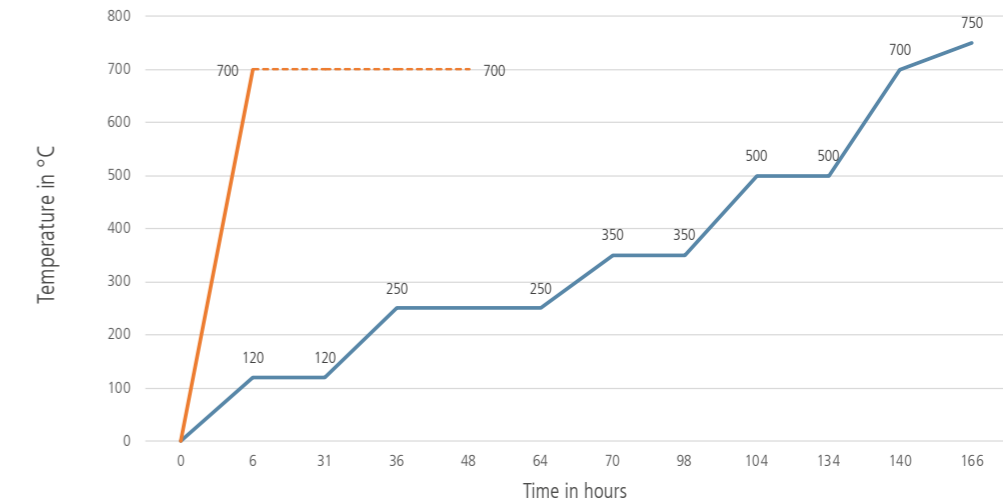

Density index

With an INSURAL installation, the desired density index of the melt can be achieved much sooner as the dry lining does not evolve hydrogen gas into the melt. The advantage is a faster integration of the furnace into the production process.

Production flexibility and capacity is improved and the production of high quality castings can be scheduled without restriction.

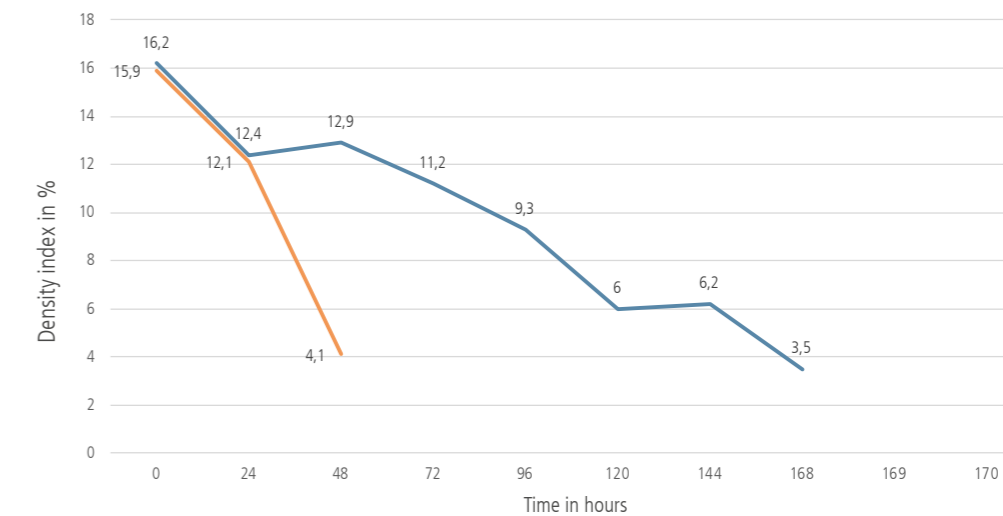

— Traditional Lining
— INSURAL



INSURAL Furnace Lining - Installation

Fast turnaround - less downtime

Installation can be carried out either on-site or at a recommended 3rd party installer.

All necessary components are delivered ready for installation. For each furnace type, the individual INSURAL components have been designed to fit exactly into the steel shell.

Some backing materials can be reused in subsequent liner installations.

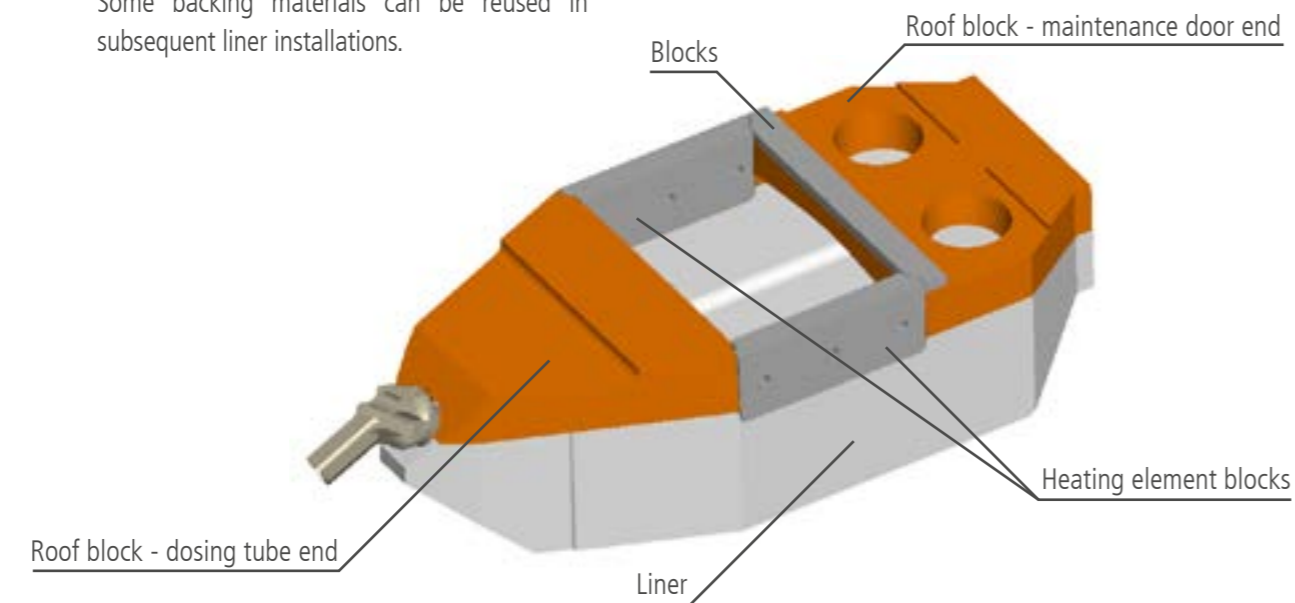

Energy consumption

The exceptional insulating properties of the INSURAL Furnace Lining System ensures that the thermal output is at a low level throughout the service life of the lining - ensuring lower energy costs, reduced carbon footprint, and excellent lining life.

Compared to monolithic lining systems, up to 17% energy savings can be achieved.

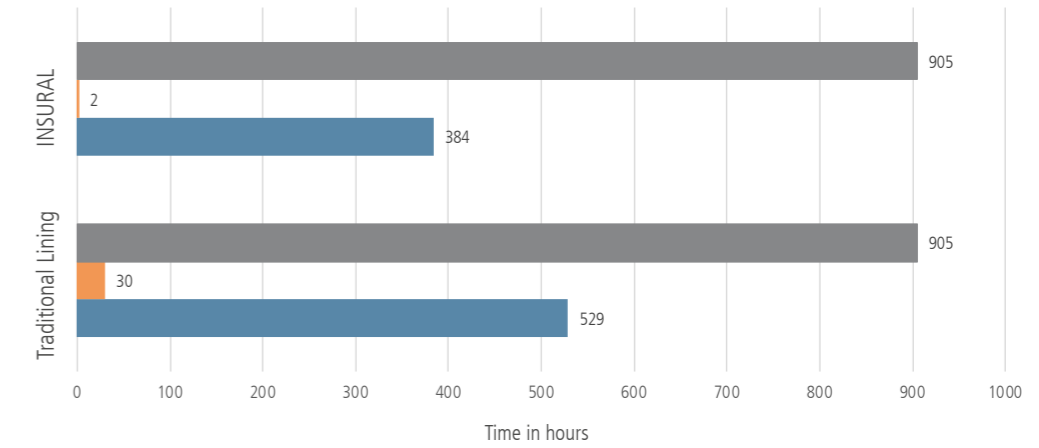
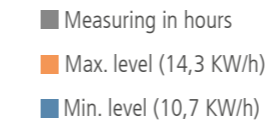

Fast turnaround - minimised downtime

The installation of a traditional monolithic lining and the sintering and pre-heating of the furnace can take up to 2 weeks. As the INSURAL lining needs no sintering and only 2 days of pre-heating; the downtime of the furnace is drastically reduced.

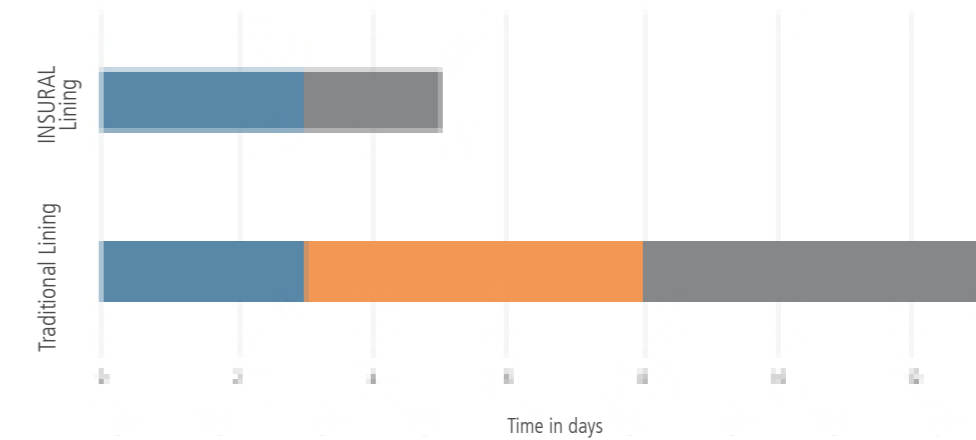



Available Furnace Systems

Our portfolio covers the following types

The existing portfolio of INSURAL linings covers a wide range of the most popular furnace types.

Since each INSURAL component is carefully designed for each furnace type, the dimensional accuracy of the finished lining is assured.

- + Dosing furnace 65 S
- + Dosing furnace 65 SL
- + Dosing furnace 90 SL
- + Dosing furnace 120 S
- + Dosing furnace 230 S
- + Dosing furnace 310 S



- + Low pressure furnace SW 800 LNS
- + Low pressure furnace WON 800 LNS

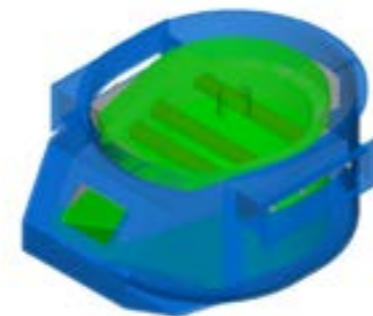

- + Dosing furnace 1050

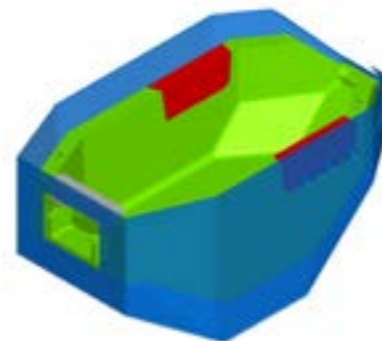

Furnace Consumables

Availability of a wide range of products

Foseco supplies a full range of consumable ceramic products for dosing furnaces, produced in a variety of INSURAL technical grades as well as other ceramic materials, for example:

- + Filling funnels
- + Dosing tubes
- + Launderers
- + Thermocouple and Heating Element Sheaths

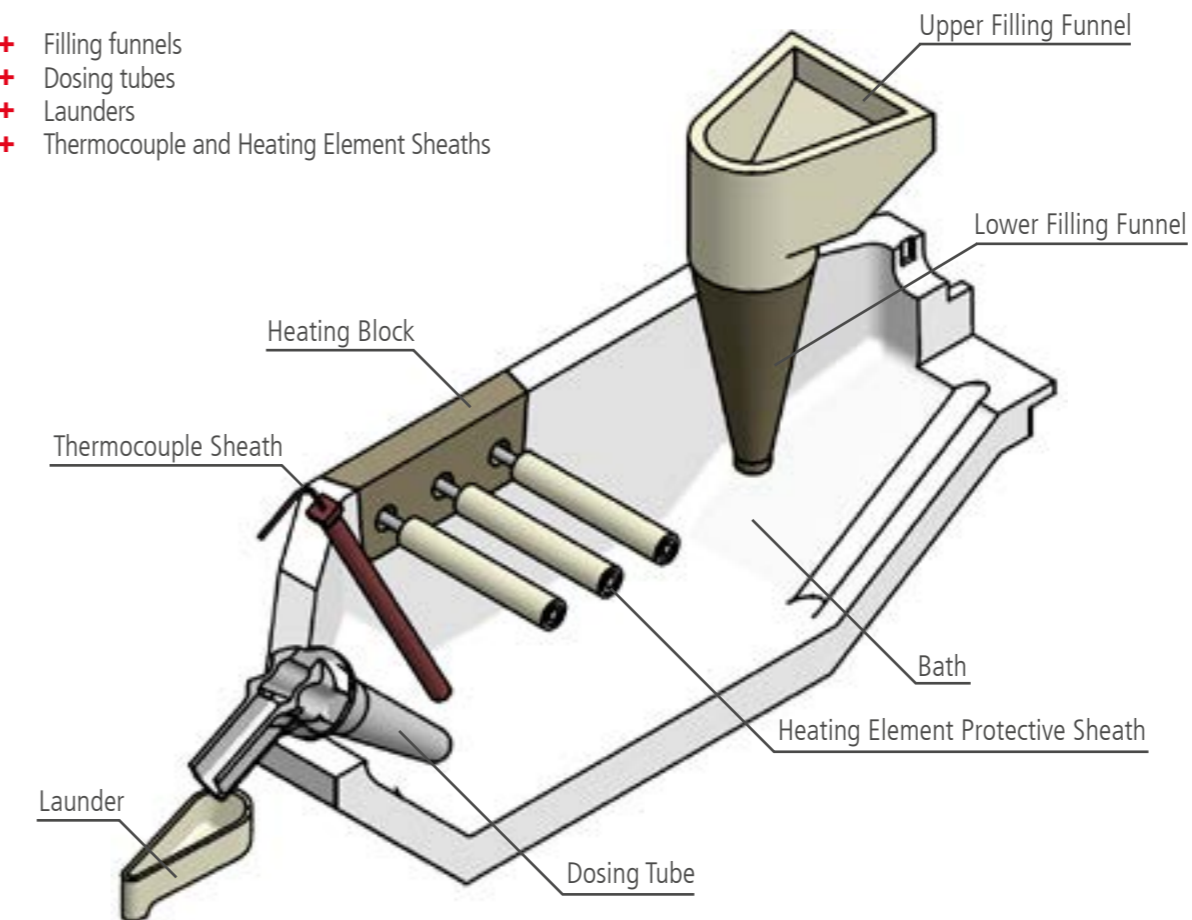

INSURAL shapes for dosing furnace – wear resistant and long service life



INSURAL all-in-one dosing tube in service



INSURAL launderers

Foseco International Limited
Drayton Manor Business Park,
Tamworth, Staffordshire,
England B78 3TL
Phone: +44 (0)1827 262021
Fax: +44 (0)1827 283725
www.foseco.com
Please contact your local Foseco team

*FOSECO, the Logo and INSURAL are trade marks of the Vesuvius Group, registered in certain countries, used under licence. All rights reserved. No part of this publication may be reproduced, stored in a retrieval system of any nature or transmitted in any form or by any means, including photocopying and recording, without the written permission of the copyright holder or as expressly permitted by law. Applications for permission shall be made to the publisher at the address mentioned.

Warning: The doing of an unauthorised act in relation to a copyright work may result in both a civil claim for damages and criminal prosecution. All statement, information and data contained herein are published as a guide and although believed to be accurate and reliable (having regard to the manufacturer's practical experience) neither the manufacturer, licensor, seller nor publisher represents nor warrants, expressly or impliedly: (1) their accuracy/reliability, (2) that the use of the product(s) will not infringe third party rights, (3) that no further safety measures are required to meet local legislation. The seller is not authorised to make representations nor contract on behalf of the manufacturer/licensor. All sales by the manufacturer/seller are based on their respective conditions of sale available on request.

© Foseco International Limited 03/19.

03/2019 - e



FOSECO. YOUR PARTNER TO BUILD ON.